

To measure $\frac{1}{4}$ of the sheet, lightly crease the centre line, and fold a corner into it.

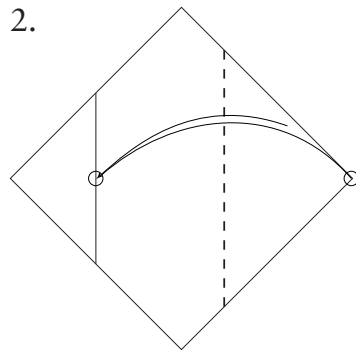

Fold and unfold.

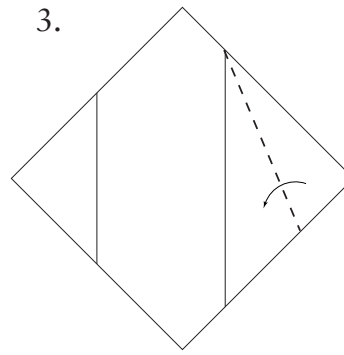

Fold the edge of the paper to the crease you made in Step 2.

Samara (Maple Key)

Marvin Goody

This fold, when tossed will spin to the ground in a spiral. Just like a real Samara!

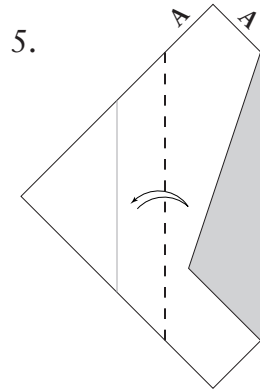
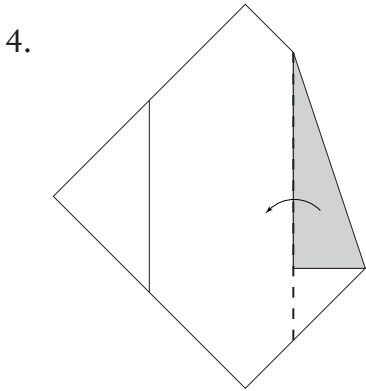

Fold so the edges marked A are of about equal distance.

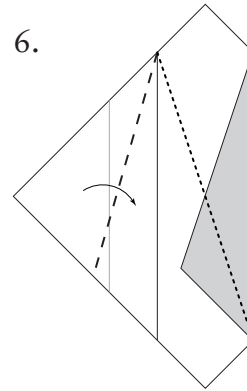

Fold the top edge to the dotted line.

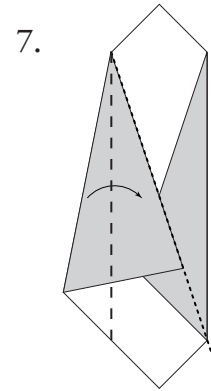

Fold the new top edge to the dotted line.

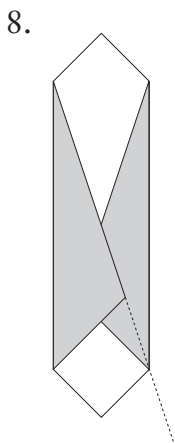

Step 7 completed.

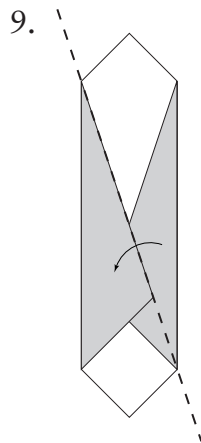

Valley fold from corner to corner.

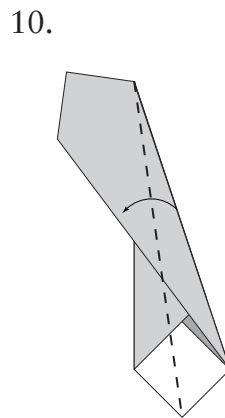

Valley fold all the layers back to the right.

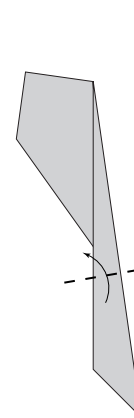

Mountain fold the tail about $\frac{3}{4}$ the way up to the body.

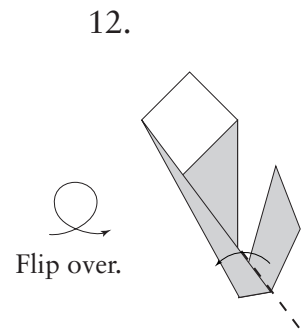

Wrap the tail around.

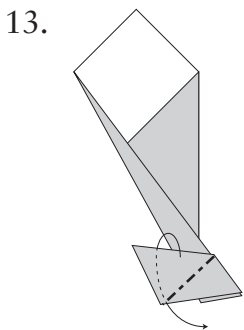

Tuck under.

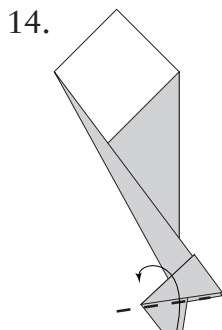

Wrap around till there is no more tail.

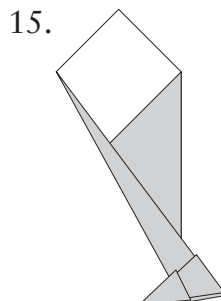

Flip over.

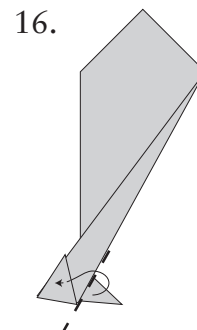

And tuck the tail into the pocket.

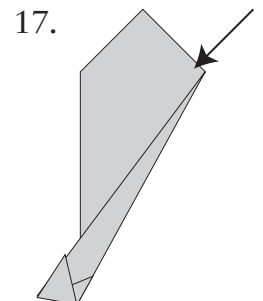

Hold the Samara at the arrow, and toss it straight into the air!